

Installation and Facilities Requirements

All site preparations are the responsibility of the customer and must be completed prior to arrival of the machine and subsequent installation.

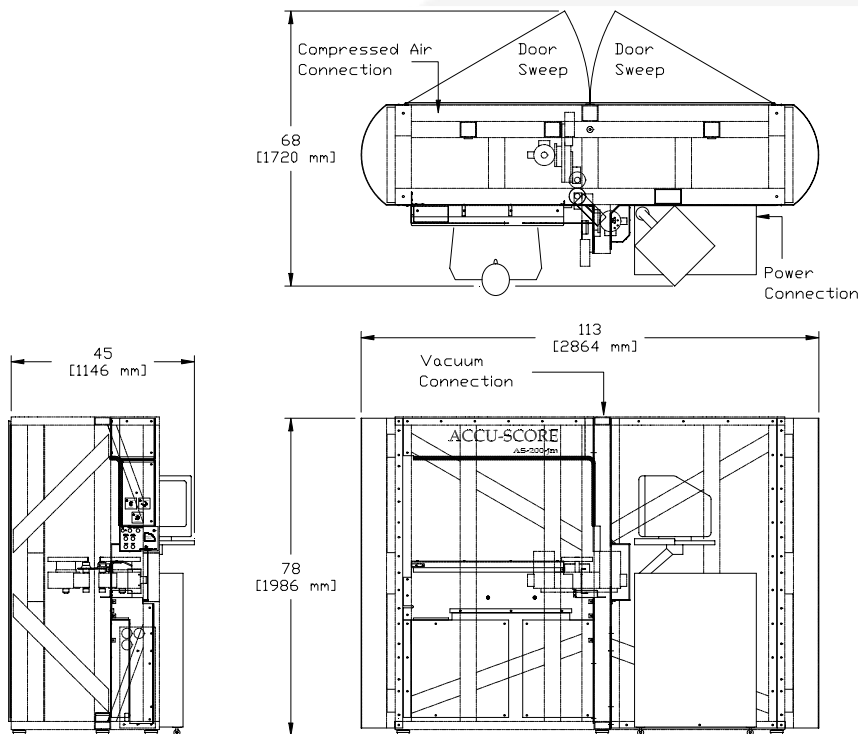

Figure 1: AS-200-JM
Overall Machine
Dimensions

Utilities & Dimensional Requirements

Specification

Power	240VAC, 10A, 50/60Hz, Single Phase, 30A Breaker Recommended (Uninterruptible power supply recommended)
Vacuum	200 CFM@ 40" Static Pressure (3" Hg)
Compressed Air	100 psi, 1 CFM, Dry
Machine Footprint	See Figure 1, 40 x 112 x 78 inches (approx.)
Wall Clearance	See Figure 1, 24 inches rear of machine and one side
Environmental	Clean, cool, and dry environment free of chemical vapors
Crated Size/Weight	120 x 48 x 84 inches/2600 lbs (approx.)

Note: Utilities are required for installation and proper machine operation.